



UNIVERSITY OF CAMBRIDGE INTERNATIONAL EXAMINATIONS  
General Certificate of Education  
Advanced Subsidiary Level and Advanced Level

CANDIDATE  
NAME

CENTRE  
NUMBER

--	--	--	--	--

CANDIDATE  
NUMBER

--	--	--	--

**PHYSICAL SCIENCE**

**8780/04**

Paper 4 Advanced Practical Skills

**For Examination from 2011**

SPECIMEN PAPER

**1 hour 30 minutes**

Candidates answer on the Question Paper.

Additional Materials: As listed in the Confidential Instructions

**READ THESE INSTRUCTIONS FIRST**

Write your Centre number, candidate number and name on all work you hand in.

Give details of the practical session and laboratory where appropriate, in the boxes provided.

Write in dark blue or black pen.

You may use a pencil for any diagrams, graphs or rough working.

Do not use staples, paper clips, highlighters, glue or correction fluid.

Answer **both** questions.

You will be allowed to work with the apparatus for a maximum of 45 minutes for each question.

You are advised to show all working in calculations.

Use of Data Booklet is unnecessary.

At the end of the examination, fasten all your work securely together.

The number of marks is given in brackets [ ] at the end of each question or part question.

<b>Session</b>
<b>Laboratory</b>

<b>For Examiner's Use</b>	
<b>1</b>	
<b>2</b>	
<b>Total</b>	

This document consists of **8** printed pages and **2** blank pages.





- 1 In this experiment you will measure the potential difference across a resistor  $R_2$  as the resistance of the circuit is varied.

(a) (i) Connect the circuit shown in Fig. 1.1 using one of the resistors in the chain.

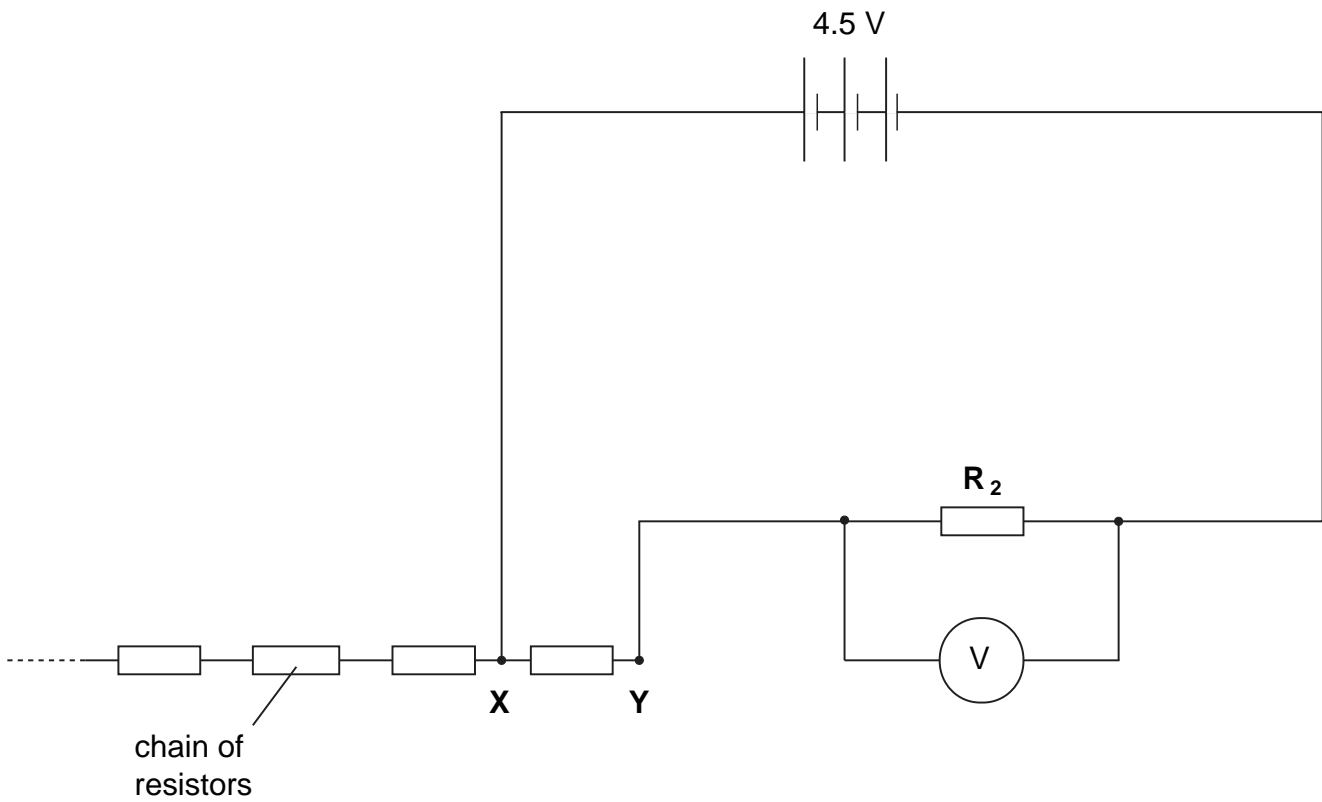

Fig. 1.1

(ii) Record the value of the potential difference  $V$  across  $R_2$ .

$V =$  ..... [1]



- (b) Change the number  $n$  of resistors between **X** and **Y** and repeat (a)(ii) until you have three sets of readings for  $V$  and  $n$ . Include values of  $1/V$  in your table of results.

For  
aminer's

- (c) (i) Plot a graph of  $1/V$  ( $y$ -axis) against  $n$  ( $x$ -axis).  
(ii) Draw the line of best fit.  
(iii) Determine the gradient and the  $y$ -intercept of the graph.

gradient = .....

 $y$ -intercept = .....

- (iv) Estimate the uncertainty in your value for the  $y$ -intercept.

uncertainty = .....

[6]

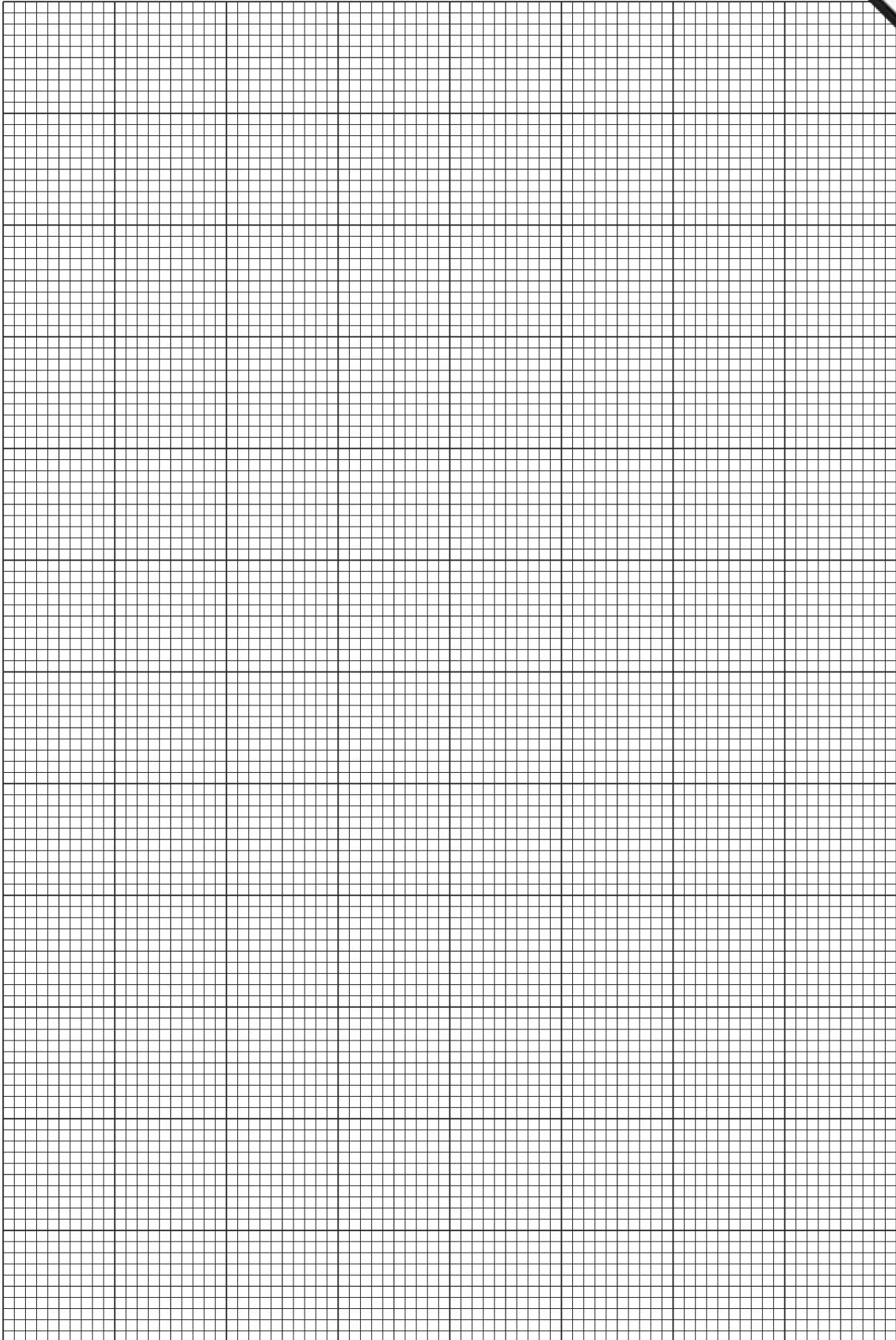

(d)  $V$  and  $n$  are related by the equation

$$\frac{1}{V} = \frac{nR_1}{ER_2} + \frac{1}{E}$$

where  $R_1$  is the resistance of each of the resistors in the chain and  $E$  is the e.m.f. of the battery.

Using your answer to (c)(iii), determine the value of  $E$ .

$E =$  ..... [1]

(e) Identify **one** significant source of error or limitation of the procedure in this experiment.

.....  
 .....  
 ..... [1]

[Total: 15]



2 (a) **P** and **Q** are aqueous solutions.

Carry out the specified tests to enable you to identify the cations present in **P** and the cations present in a mixture of **P** and **Q**.

At each stage of any test you are to record details of the following:

- colour changes seen
- the formation of any precipitate
- the solubility of such precipitates in an excess of the reagent added.

You should indicate clearly at what stage in a test a change occurs.

**No additional tests for ions present should be attempted.**

- (i) To 1 cm depth of **P** in a boiling-tube, add an equal volume of **Q**. Mix thoroughly by gently shaking the tube.
- (ii) Using the supplied bench reagents you are to identify the cation present in **P**, and the cation present in the mixture of **P** and **Q**.

Record all of your observations in the table below.

<i>test</i>	<i>observations</i>	
	<b>P</b>	mixture of <b>P</b> and <b>Q</b>
To 1 cm depth of solution in a test-tube add, drop by drop, 1 cm depth of bench reagent aqueous sodium hydroxide.  Stir the mixture, then add a further 1 cm depth of bench reagent aqueous sodium hydroxide.		
To 1 cm depth of solution in a test-tube add, drop by drop, 1 cm depth of bench reagent aqueous ammonia.  Stir the mixture, then add a further 1 cm depth of bench reagent aqueous ammonia.		

(iii) **Conclusions**

The cation present in **P** is .....

The cation present in the mixture of **P** and **Q** is .....

When **P** and **Q** reacted together, **Q** was acting as .....

[5]

--

- (b) You are to carry out a titration to determine the concentration of ethanoic solution **X**.

You are provided with the following:

solution **X**, aqueous ethanoic acid, of unknown concentration  
aqueous sodium hydroxide containing  $3.40 \text{ g dm}^{-3}$  NaOH  
phenolphthalein indicator.

#### Dilution of X

- (i) Use a burette to measure between  $38.00 \text{ cm}^3$  and  $39.00 \text{ cm}^3$  of solution **X** into the  $250 \text{ cm}^3$  volumetric flask labelled **Y**.  
Record your burette readings and the volume of solution **X** added to the flask in the space below.

Make up the contents of the flask to the  $250 \text{ cm}^3$  mark with distilled water. Place the stopper in the flask and mix the contents thoroughly by slowly inverting the flask a number of times.

#### Titration

- (ii) Fill a second burette with solution **Y**, the diluted solution of ethanoic acid.

Pipette  $25.0 \text{ cm}^3$  of the  $3.40 \text{ g dm}^{-3}$  sodium hydroxide into the conical flask and add 2 to 3 drops of phenolphthalein indicator.

Titrate the sodium hydroxide in the flask with solution **Y** until the solution just turns colourless.

**Perform a rough (trial) titration and sufficient further titrations to obtain accurate results.**

Record your titration results in the space below. Make certain that your recorded results show the precision of your working.



- (iii) From your titration results obtain a volume of solution **Y** to be used in your calculations.  
Show clearly how you obtained this volume.

volume of **Y** = ..... cm<sup>3</sup>  
[6]

### Calculations

Show your working and appropriate significant figures in all of your calculations.

- (iv) The aqueous sodium hydroxide contains 3.40 g dm<sup>-3</sup> NaOH.

Calculate how many moles of NaOH have been pipetted into the conical flask in (b)(ii).

[A<sub>r</sub>: H, 1.0; O, 16.0; Na, 23.0]

amount of NaOH = ..... mol

- (v) Ethanoic acid is a monoprotic (monobasic) acid.

Use your titre volume in (b)(iii) and the answer to (iv) above to calculate how many moles of ethanoic acid are contained in 250 cm<sup>3</sup> of solution **Y**.

amount of ethanoic acid in 250 cm<sup>3</sup> of **Y** = ..... mol

- (vi) Use your answer to (v) to calculate the concentration, in mol dm<sup>-3</sup>, of the undiluted ethanoic acid in solution **X**.

concentration of ethanoic acid in **X** = ..... mol dm<sup>-3</sup>  
[4]

[Total: 15]

